

POS.	Q.	DESCRIPTION	MODEL	ELECTRICITY MONOPHASE			GAS		
				POWER	VOLTAGE	HEIGHT	POWER	DIM.	HEIGHT
<b>S-COOKING AREA</b>									
S.44	2	S/S WORKTOP WITH STORAGE BASE CW	CEM-18.0	3.0	120				
S.45	2	S/S TUBULAR POT RACK	CUSTOM						
S.46	3	20 HOT TOP SECTION W/ STANDARD OVEN BASE	C306-10	0	0	120,000	12"	0	MTWA
S.47	1	RANGE MATCH-CHARBROILER W/ STORAGE BASE	CR36-18A	0	0	97,000	12"	0	MTWA
S.48	1	11 HOT TOP SECTION ON LEFT AND 12" OPEN BURNER	C306-17	0	0	115,000	12"	0	MTWA
S.50	1	SINGLE RANGE MATCH FRONT	CR36-10SF			110,000	12"	0	MTWA
S.51	1	ELECTRIC FINISHING OVEN	SEM-00	2.5	208				
S.52	2	PANNO DI LAVORO SPECIALE	BYT						
S.53	2	ELECTRIC BALANCE/ADJUSTABLE TOP 600MM	SAL-06	7.5	230/7N	1000			
S.54	1	WARMING CABINET	HRAND-SPECIAL						
S.55	1	ELECTRIC FINISHING OVEN	SEM-00	2.5	208				
S.56	1	WARMING CABINET	HRAND	1.25	120				
S.56	3	POT FILL FAUCET	KF7-9018						
S.57	1	12 HOT GRIDDLE W/ STORAGE BASE MODIFIED TO HAVE DR	CR48S-1-1	0	0	77,000	12"	0	MTWA
S.58	1	PRIMAIRE GAS PASTA COOKER COOKER ONLY	GC-80	0.9	120	80,000	12"	0	MTWA
Total (Alternative and Option excluded)				18.38		1,128,000			

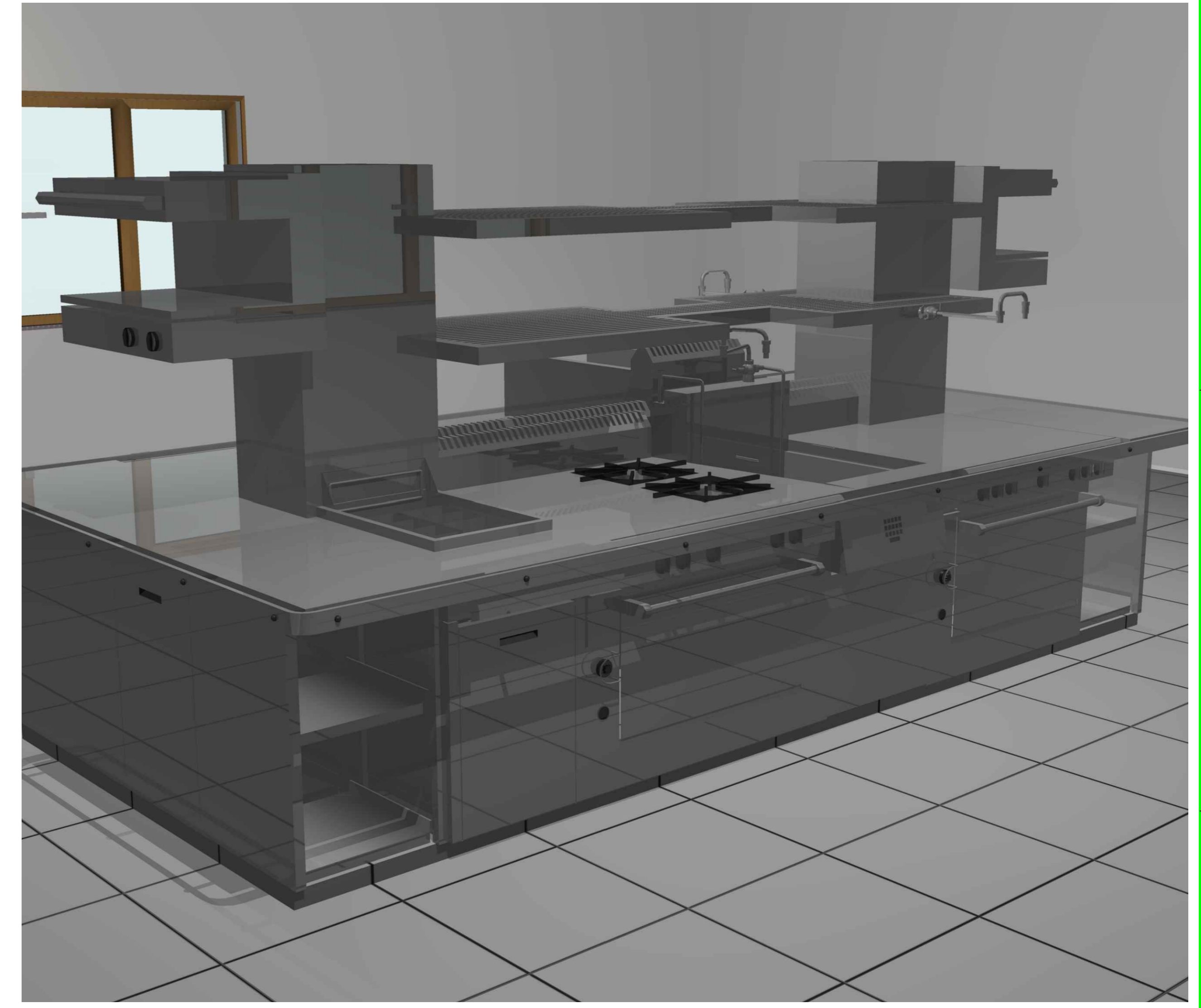
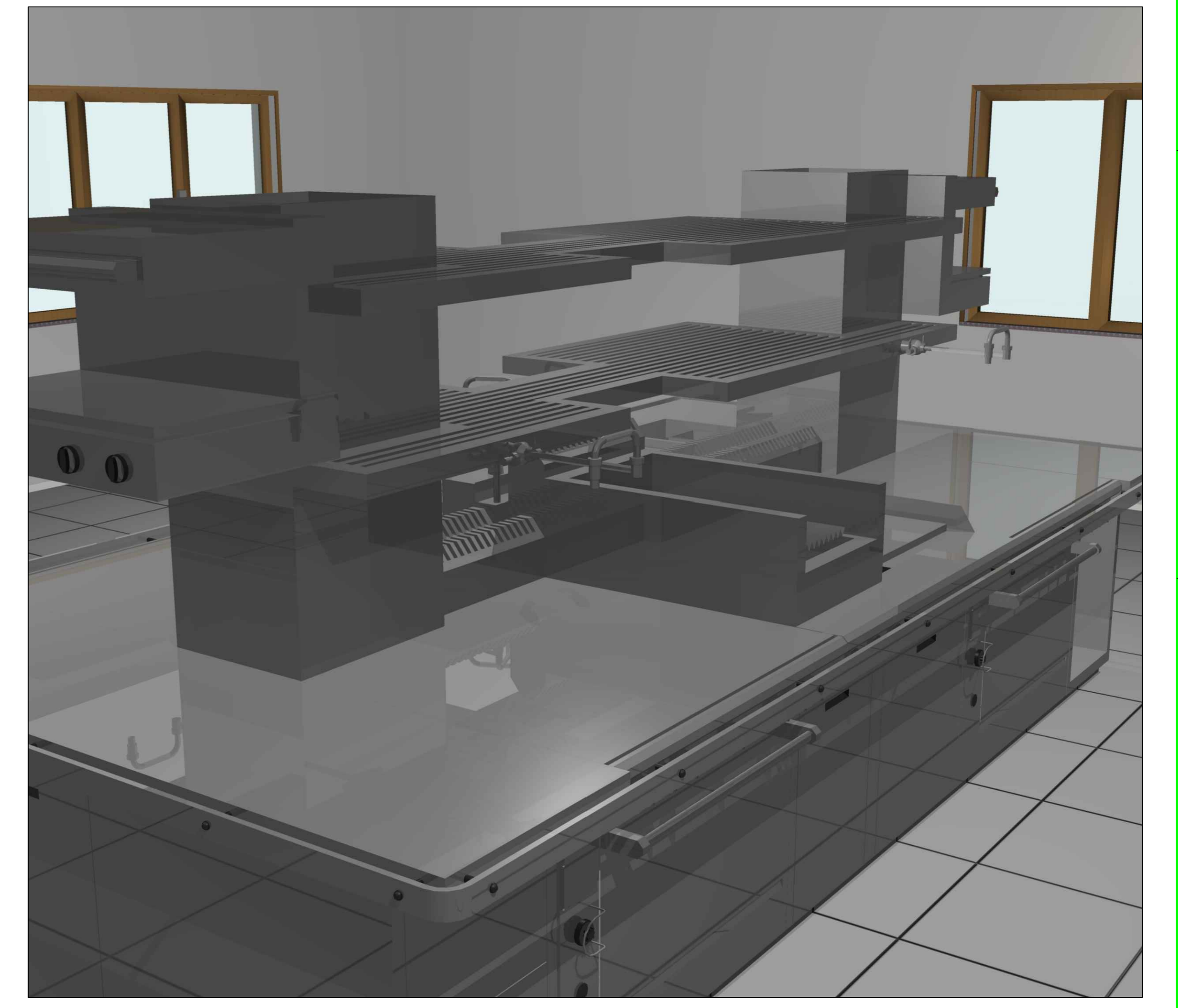
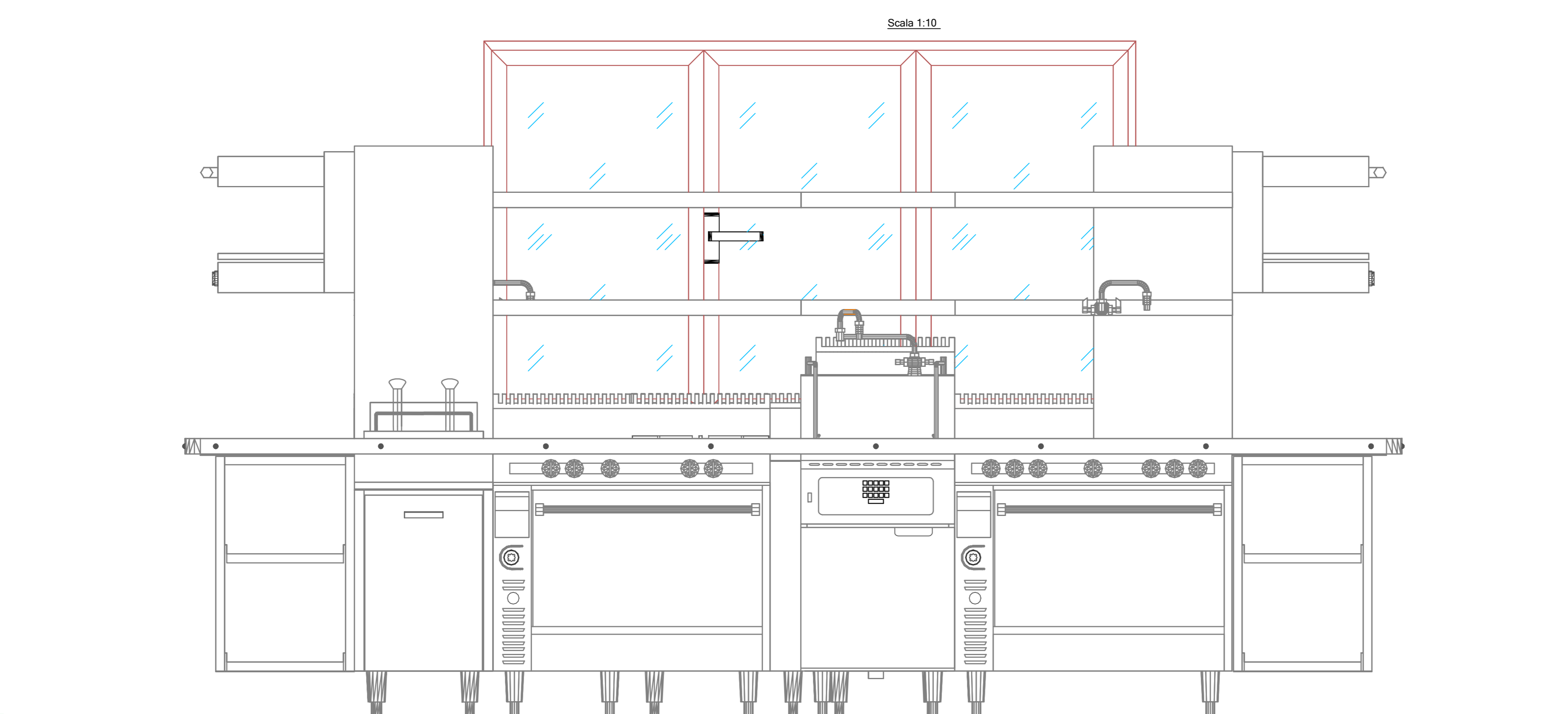
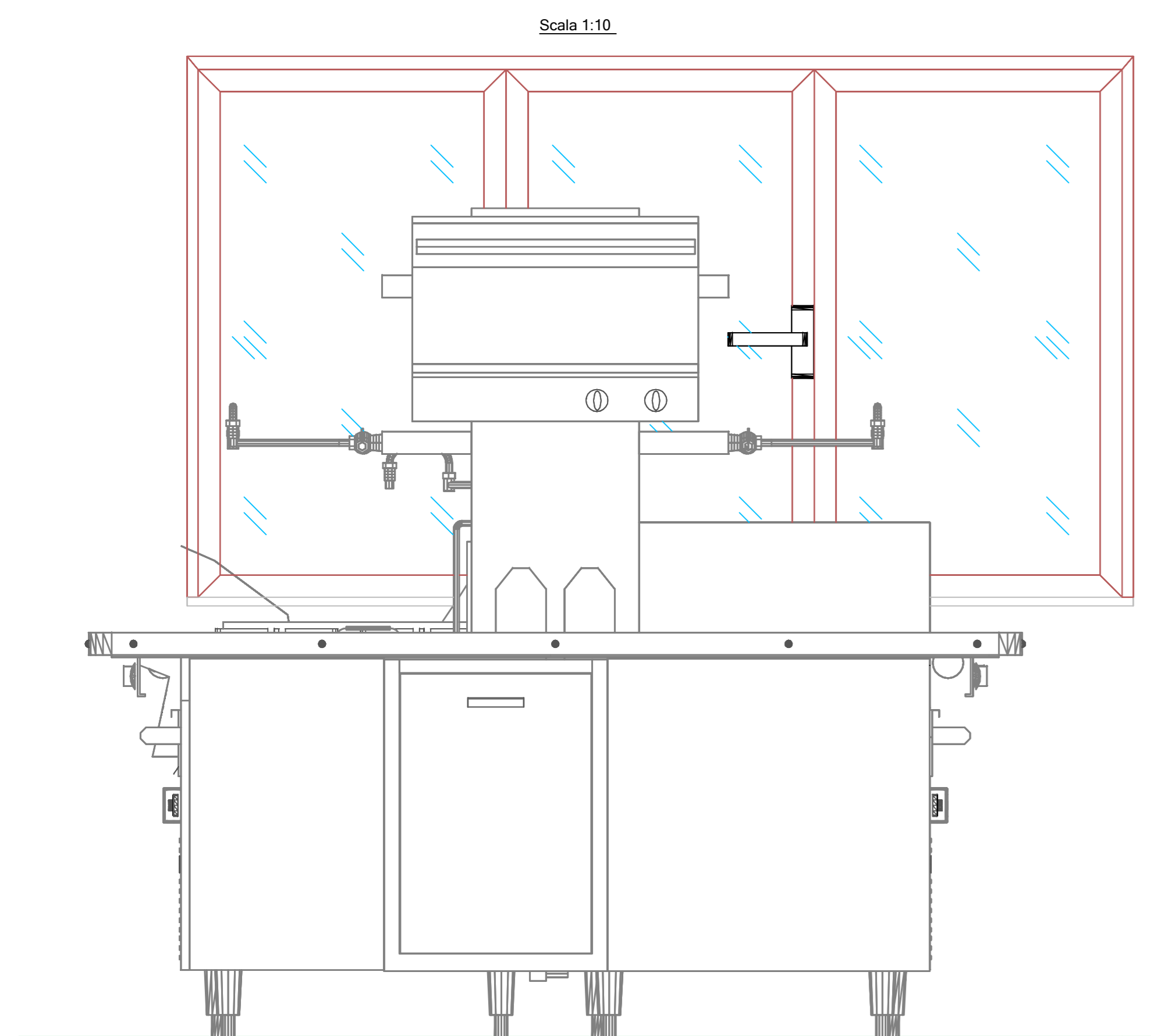
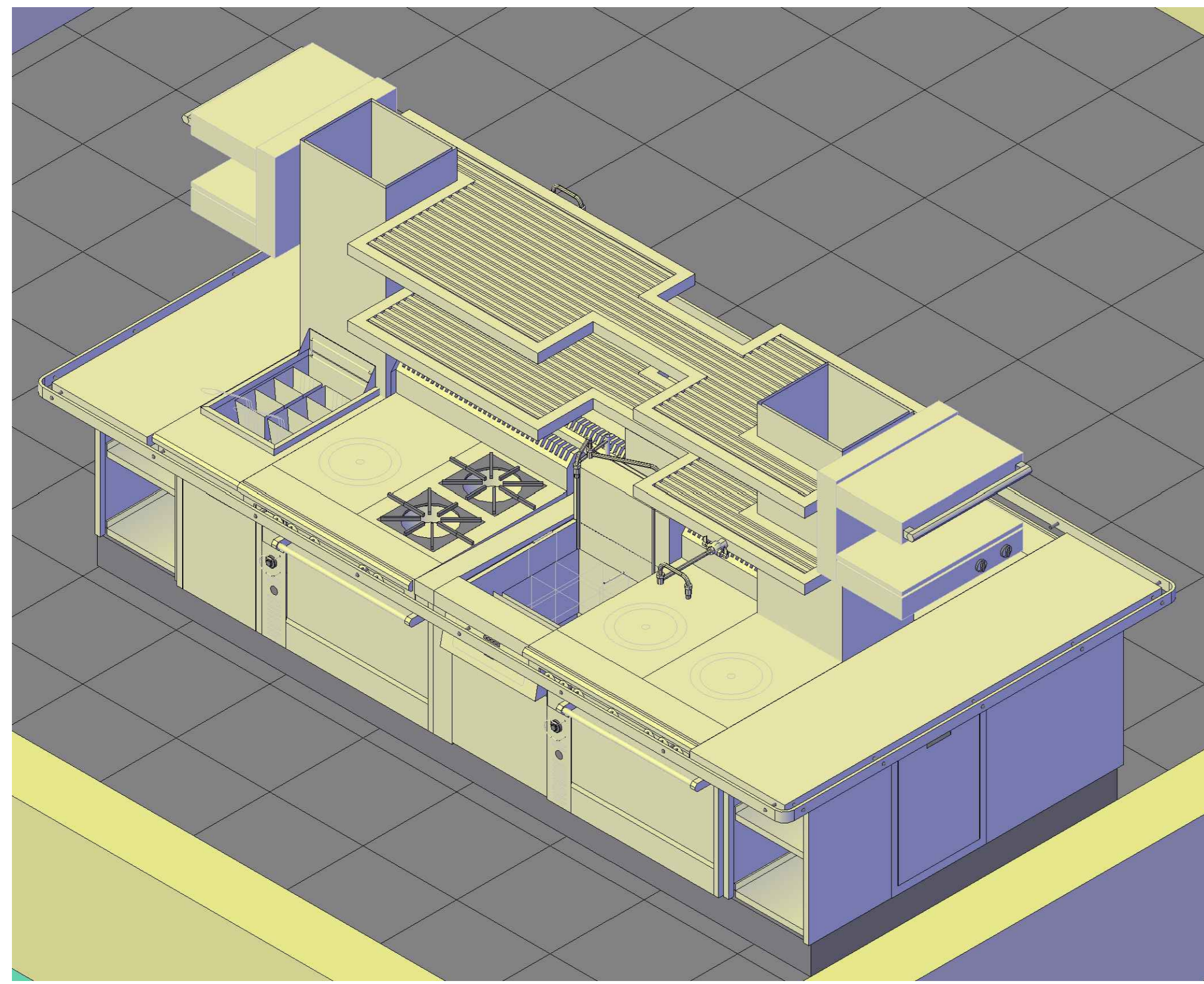

**RENDERIMAGE**

DEMO MASTERCHEF

\_CUCINA\_  
LAYOUT

DISEGNO N°	REVISIONE
0000000	RIF. LAYOUT 0000000